

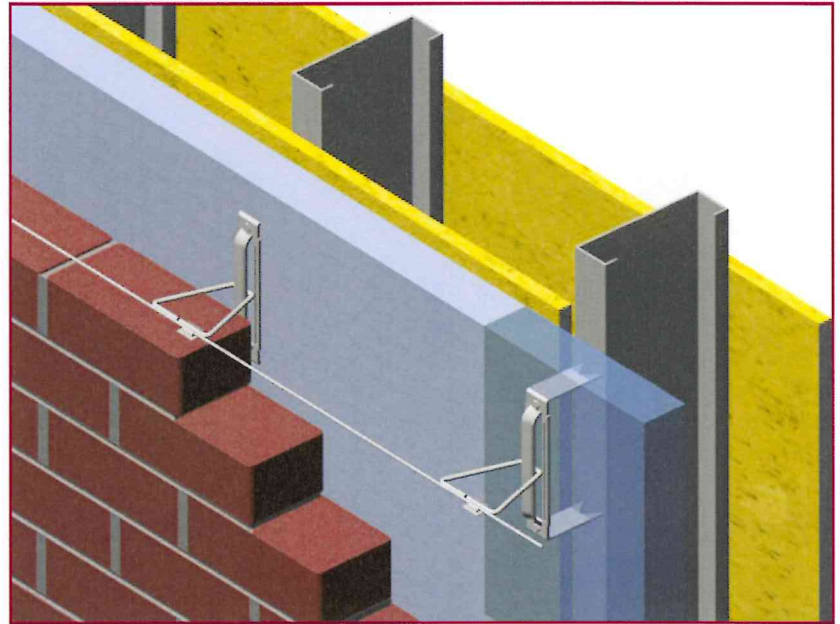

# PRODUCT SUBMITTAL

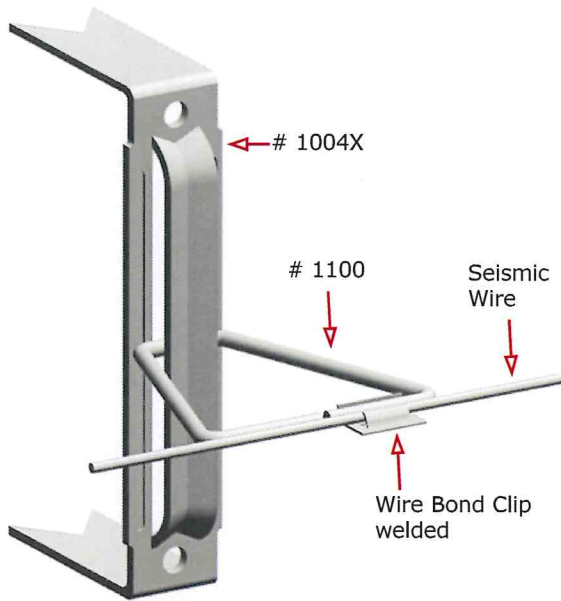

## # 1004X Type III X Screw On Veneer Anchor Seismic



MATERIAL CONFORMANCE	SIZES / FINISHES
<p><b>SHEET METAL - (Carbon Steel) ASTM A1008 / A1008M</b></p> <p>Mill Galvanized / Zinc Coating: <b>ASTM A641 / A641M (0.10 Oz per sq ft)</b></p> <p>Hot Dip Galvanized after fabrication / Zinc Coating <b>ASTM A153 / A153M-B2 (1.50 oz per sq ft)</b></p> <p>Stainless Steel <b>ASTM 580 / ASTM 580M Type 304</b> (Type 316 available on special order)</p> <p><b>ASTM A82 / A82M - (Cold drawn steel wire)</b> Tensile Strength - 80,000 psi Yield Point - 70,000 psi</p> <p><b>ACI / ASCE 530 - (Building code requirements for masonry structures)</b></p>	<p><b># 1004 Type III X:</b> 1-1/4" wide x 6" long</p> <p><input type="checkbox"/> 14 gauge    <input type="checkbox"/> 12 gauge</p> <p>(Prong length to accommodate insulation)</p> <p><b>INSULATION:</b></p> <p><input type="checkbox"/> 1"    <input type="checkbox"/> 1-1/2"    <input type="checkbox"/> 2"    <input type="checkbox"/> 2-1/2"    <input type="checkbox"/> 3"</p> <p><b># 1100 Triangle:</b></p> <p><input type="checkbox"/> 3/16" dia.    <input type="checkbox"/> 1/4" dia.</p> <p><input type="checkbox"/> 3"x3"    <input type="checkbox"/> 4"x4"    <input type="checkbox"/> 5"x5"    <input type="checkbox"/> 6"x6"    <input type="checkbox"/> 7"x9"    <input type="checkbox"/> 9" x 9"</p>
<p><b>Steel Products (flats):</b> Mill Galvanized &amp; Hot Dip, 59.2% Post-Consumer 8.8% Post Industrial / Pre - Consumer</p> <p>Stainless Steel, 60% Post Consumer V O C Content - 0%</p> <p><b>WIRE Recycled Content:</b> Mill Galvanized &amp; Hot Dip, 85% Post-Consumer 13% Post Industrial / Pre - Consumer</p> <p>Stainless Steel, 60% Post Consumer V O C Content - 0%</p>	<p><b>Straight &amp; Cut Seismic Wire</b></p> <p><input type="checkbox"/> 9 gauge    <input type="checkbox"/> 3/16" dia.</p> <p><b>FINISH:</b></p> <p><input type="checkbox"/> Mill Galvanized    <input type="checkbox"/> Hot Dip Galvanized    <input type="checkbox"/> Stainless Steel</p> 



**MASONPRO, Inc.**  
Northville, MI 48167  
1-800-659-4731  
www.masonpro.com