

PRODUCT SUBMITTAL

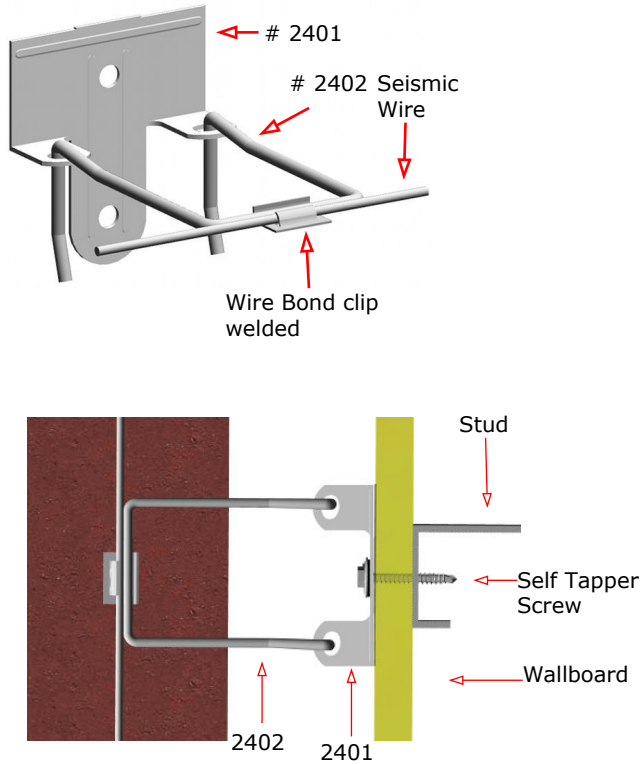

2401 RJ-711 Adjustable Veneer Anchor Seismic



Tying Masonry To Steel Stud

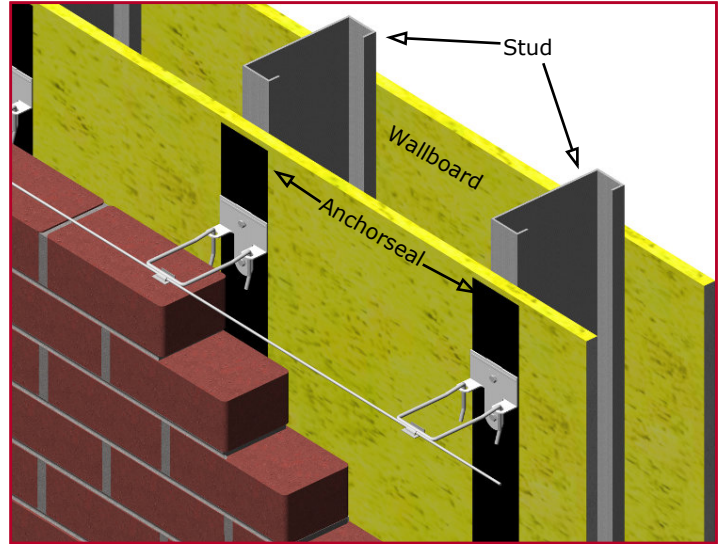

MATERIAL CONFORMANCE	SIZES / FINISHES
<p>ASTM A82 / A82M - (Cold drawn steel wire) Tensile Strength - 80,000 psi Yield Point - 70,000 psi</p> <p>ACI / ASCE 530 - (Building code requirements for masonry structures)</p> <p>SHEET METAL - (Carbon Steel) ASTM A1008 / A1008M Mill Galvanized / Zinc Coating: ASTM A641 / A641M (0.10 Oz per sq ft) Hot Dip Galvanized after fabrication / Zinc Coating ASTM A153 / A153M-B2 (1.50 oz per sq ft)</p> <p>Stainless Steel ASTM 580 / ASTM 580M Type 304 (Type 316 available on special order)</p> <p>Steel Products (flats): Mill Galvanized & Hot Dip, 59.2% Post-Consumer 8.8% Post Industrial / Pre - Consumer</p> <p>Stainless Steel, 60% Post Consumer V O C Content - 0%</p> <p>WIRE Recycled Content: Mill Galvanized & Hot Dip, 85% Post-Consumer 13% Post Industrial / Pre - Consumer</p> <p>Stainless Steel, 60% Post Consumer V O C Content - 0%</p>	<p># 2401 RJ711:</p> <p>14 gauge 12 gauge</p> <p># 2402 Hook: 3/16" Diameter Standard</p> <p>3-1/4" 4-1/4" 5-1/4" Other _____</p> <p>Straight & Cut Seismic Wire:</p> <p>9 gauge 3/16" Diameter</p> <p>FINISH: Mill Galvanized Hot Dip Galvanized Stainless Steel</p> 

Corporate Office: 400 Rountree Rd Charlotte, NC 28217
TEL: (800) 849-6722 FAX: (704) 525-3761

Mailing Address: P.O. Box 240988 Charlotte, NC 28224



www.wirebond.com

Memphis Plant: 2365 Harbor Ave. Memphis, TN 38113
TEL: (800) 441-8359 FAX: (901) 775-9449

Mailing Address: P.O. Box 13124 Memphis, TN 38113