

PRODUCT DATA SHEET
Lap Rite™

One Part Non-Skinning Butyl Metal Flashing Sealant



Description

Lap Rite™ is a one part non-skinning butyl metal flashing sealant.

Basic Use

- Sealing metal thru-wall flashing laps.

Benefits

- Withstands severe weather conditions
- Performs in a wide temperature range
- Allows metal lap joints to expand and contract

Packaging

Lap Rite™ is supplied in 10.5 fl. oz. cartridges. Available in gray. Packaged 12 cartridges per carton.

Joint Design

Sealant bead should be no thinner than 1/4" diameter.

Joint Preparation

Metal joints to receive sealant must be sound, smooth, uniform in dimension and free from defects and foreign material. They must be clean, dry and free of frost and all contaminants, such as curing compounds, sealers (waterproofing), coatings, etc.

Application Instructions

Cut conical tip off of cartridge end at 45° to required size and place into a standard caulking gun. Puncture inner seal. Extrude two 1/4" diameter beads spaced 1" from the lap and 1" in between. Extend the beads from the face of the drip edge, across the horizontal plain and vertically up the back leg. Press the two layers of metal tightly to form a water tight seal. If application temperature is below 40° F (5° C), precautions should be taken to ensure the substrates are completely dry and frost free. Do not apply on wet substrate.

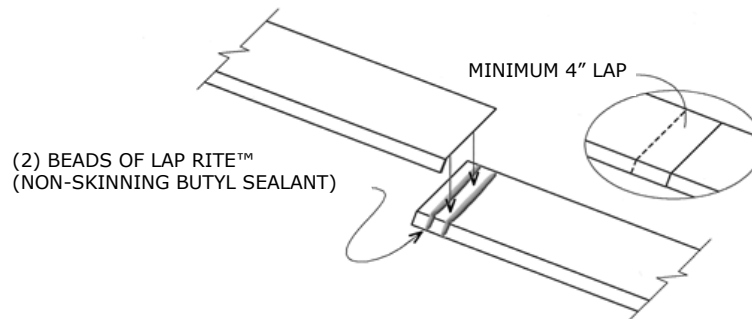

Health & Safety The following precautions should be taken:

- Wear gloves and eye protection
- Use only in well ventilated areas
- Any eye contact should be treated by rinsing with clean water and medical advice should be sought.
- Follow individual Material Safety Data Sheet (MSDS) health and safety precautions.
- Avoid ingestion or inhalation of vapors
- Keep out of reach of children
- If accidental contact with skin should occur, skin should be cleaned immediately with soap and water.
- Wash hands prior to eating or smoking

Limitations • Not for use in submerged applications • Surfaces must be clean and dry

Clean Up With VM&P Naphtha or Mineral Spirits.

Technical Data		
Physical Properties		
	Typical Values	Test Method
Base Polymer	Synthetic Rubber	FTIR
Aged Tack	Permanently Tacky	ASTM D 2377
Shrinkage	20% Maximum	ASTM D 2453
Sag	0.15" Maximum at 158° F	ASTM D 2202
Peel Strength	>0.5 pli with no loss of bond	ASTM C 794
Press-Flow Viscosity	40 Seconds Maximum	ASTM D 2452 (modified)
Hardness	30 - 40	Shore 00 Durometer
Adhesion	Excellent to most clean surfaces.	ASTM C 794
Weathering	Very slight color change; No adhesion loss, no cracking, no wrinkling or oil exudation.	ASTM G 53, QUV Chamber
Water Immersion	No adhesion loss, no shrinkage, no chalking.	ASTM D 870
Flash Point	105° F (40° C)	ASTM D 56
VOC Content	53 grams/Liter = 0.44 pounds per gallon (4% maximum)	ASTM D 3960
Solids Content	85% Minimum	ASTM C 681
Weight / Gallon	10.5 +/- 0.40 lbs	ASTM D 1475
Specific Gravity	1.26 +/- 0.05	ASTM D 1475
Application Data		
Service Temperature	-40° F to 250° F	ASTM C 1257
Application Temperature	40° F to 95° F	ASTM C 603
Storage	40° F to 90° F	ASTM D 1337
Shelf Life	One Year	ASTM D 1337
<p>Note: The foregoing information is published as general information only. The listed properties and performance characteristics are approximate values and are not part of the product specification.</p>		

Technical Service For further technical information, advice on suitability for specific applications, or detailed Health and Safety information, contact MASONPRO.

IMPORTANT NOTE While all reasonable care is taken in compiling technical data on the company's products, all recommendations regarding the use of such products are made without guarantee since the conditions of use are beyond the company's control. It is the customer's responsibility to satisfy themselves that each product is fit for the purpose for which they intend to use it.