

# PERM-A-BARRIER<sup>®</sup> NPS Wall Membrane (US Version)

MASONPRO, Inc.  
43300 Seven Mile Road  
Northville, MI 48167  
1-800-659-4731  
www.masonpro.com

Primer-less self-adhered air & vapor barrier membrane

[Contact an Air Barrier Specialist today](#)

## Product Description

PERM-A-BARRIER<sup>®</sup>NPS (Non Permeable Sheet) Wall Membranes are ideal for protecting the building superstructure from the damaging effects of the elements. By minimizing air and water vapor flow through the building exterior, PERM-A-BARRIER<sup>®</sup>NPS Wall Membranes:

- Prevent premature deterioration of the building envelope
- Enhance thermal performance of the structure and save energy costs
- Improve comfort for the building occupants

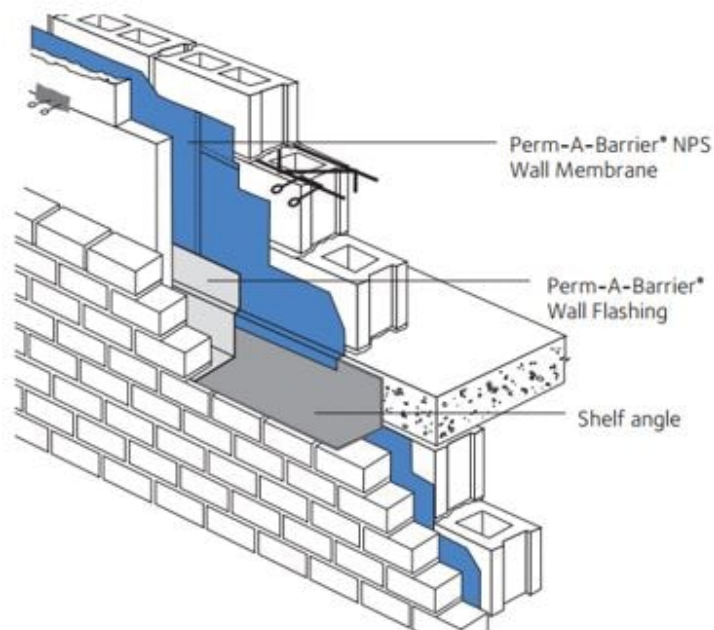

## Product Advantages

- Primer-less self-adhered sheet—reduces installation time by up to 40%
- Fire Resistant—meets NFPA 285 as part of various wall assemblies with foam plastic insulation
- Fully bonded—transmits wind loads directly to the substrate
- Waterproof and virtually impermeable to moisture—virtually impermeable to the passage of liquid water and vapor
- Air tight— Protects against air passage and associated energy losses. Meets ASTM E2357 standard as required by IECC 2012

- **Flexible**—accommodates minor settlement and shrinkage movement
- **Controlled thickness**—factory made sheet ensures constant, non-variable site application
- **Aggressive, conformable adhesive**—allows selfsealing around mechanical fasteners
- **Wide application window**— primerless application at surface and ambient temperatures of 25 °F (-4 °C) and above.

## System Components

- **PERM-A-BARRIER® NPS Wall Membrane**— for use at installation temperatures above 25 °F (-4 °C)
- **PERM-A-BARRIER® Adhesive** - Adhesive for difficult to bond areas
- **PERM-A-BARRIER® S100 Sealant**—one part neutral curing, ultra low modulus silicone sealant for sealing penetrations, terminations, brick ties and final terminations
- **BITUTHENE® Mastic**—rubberized asphalt mastic for sealing penetrations, terminations, brick ties, etc.
- **BITUTHENE® Liquid Membrane**—two component, trowel grade, asphalt modified urethane for sealing patches, terminations, brick ties, etc.
- **PERM-A-BARRIER® Wall Flashing**—fully adhered through wall flashing system
- **PERM-A-BARRIER® NPS Flashing**—fully adhered flashing for protecting and sealing critical detail areas

## Installation

### Safety

PERM-A-BARRIER® products must be handled properly. Vapors from the mastic and solvent-based primer are harmful and flammable. For these products, the best available information on safe handling, storage, personal protection, health and environmental considerations has been gathered. Refer to product label and Safety Data Sheet before use. All users should acquaint themselves with this information prior to working with the material. Carefully read detailed precaution statements on the product labels and SDS before use. SDSs can be obtained from our web site or by contacting us toll free at 866-333-3SBM (3726).

### Surface Preparation

Surface must be smooth, clean, dry and free of voids, spalled areas, loose aggregate, loose nails, sharp protrusions or other matter that will hinder the adhesion or regularity of the wall membrane installation. Clean loose dust or dirt from the surface to which the wall membrane is to be applied by wiping with a clean, dry cloth or brush. In cold temperature installations do not apply over ice or frost. It is best practice to spray primer or adhesive onto gypsum cut edge to reduce dust. Ensure solvent flashes off completely before applying Perm-A-Barrier NPS

GCP Applied Technologies Perm-A-Barrier products are ideal for a wide variety of substrates, including, but not limited to, block, poured concrete, gypsum, plywood and OSB. Please contact your local GCP Applied Technologies Representative for any questions regarding other substrates.

Certain substrate conditions may require the use of a GCP primer. Contact your local GCP Applied Technologies Representative for information.

## Temperature

PERM-A-BARRIER®NPS Wall Membrane may be applied without primer to dry substrate when air and surface temperatures are above 25 °F (-4 °C).

## Membrane Application

Cut membrane into easily handled lengths. Apply membrane horizontally or vertically to substrates receiving post-applied masonry anchors (ties), such as gypsum sheathing.

Apply PERM-A-BARRIER®NPS Wall Membranes horizontally to blockwork with projecting masonry anchors (ties), beginning at the base of the wall. Each length of the membrane must be installed so that the upper edge runs continuously along the underside of the line of masonry anchors (ties). Subsequent sheets applied above must overlap the sheet below by 2 in. (51 mm) immediately below the line of anchors (ties). Since the membrane width appropriate for this application of 18 in. (457 mm) is wider than the typical spacing between the lines of anchors (ties) 16 in. (406 mm), it will be necessary to cut the membrane at the location of the tie wires projecting from the wall to enable the sheet to be laid in place. End laps that occur in subsequent lengths that follow should maintain a minimum overlap of 2 in. (51 mm). See Figures 1 and 2.

The membrane must be pressed firmly into place with a hand roller or the back of a utility knife as soon as possible, ensuring continuous and intimate contact with the substrate to prevent water from migrating under the membrane.

In certain applications such as on soffits, ceilings or substrates such as oriented strand board (OSB), backnail the membrane along the side lap prior to installing the next sheet of membrane to ensure positive contact to the substrate.

Additional fastening may be required through the field of the membrane in these applications and must be sealed with Perm-A-Barrier S100 Sealant, BITUTHENE®Liquid Membrane or BITUTHENE®Mastic.

Apply PERM-A-BARRIER®S100 Sealant, BITUTHENE®Mastic or BITUTHENE®Liquid Membrane to seal around the tie wire projections. Fit the PERM-A-BARRIER®NPS Wall Membrane tightly around all penetrations through the membrane and seal using PERM-A-BARRIER®S100 Sealant or BITUTHENE®Liquid Membrane.

Continue the membrane into all openings in the wall area, such as windows, doors, etc., and terminate at points that will prevent interior visibility. The installation must be made continuous at all framed openings.

Coordinate installation of the PERM-A-BARRIER®NPS Wall Membrane with the roofing trade to ensure continuity with the roofing system at this critical transition area.

At the end of each working day, if the wall has been only partially covered, apply a bead of BITUTHENE®Mastic or BITUTHENE®Liquid Membrane along the top edge of the membrane at its termination to prevent vertical drainage of precipitation from penetrating the end and undermining the membrane adhesion. Tool the BITUTHENE®Mastic or BITUTHENE®Liquid Membrane to ensure it is worked into the surface. For final terminations that will not be covered with membrane, PERM-A-BARRIER®S100 Sealant can be used in lieu of BITUTHENE®Mastic or BITUTHENE®Liquid Membrane. Inspect the membrane before covering and repair any punctures, damaged areas or inadequately lapped seams.

All non water shedding edges must be sealed with PERM-A-BARRIER®S100 Sealant, BITUTHENE®Liquid Membrane or BITUTHENE®Mastic.

### Membrane Repairs

Repairs must be made using PERM-A-BARRIER®NPS Wall Membrane sized to extend 6 in. (150 mm) in all directions from the perimeter of the affected area. The repair piece must be pressed into place with a hand roller as soon as possible to ensure continuous and intimate contact with the substrate. To repair gaps which are less than 1/8 inch in diameter (fish mouth gaps) cover with Perm-A-Barrier Mastic extending 2 inches in diameter from the gap.

### Membrane Protection

PERM-A-BARRIER®NPS Wall Membranes must be protected from damage by other trades or construction materials.

Figure 1: Membrane System Detail

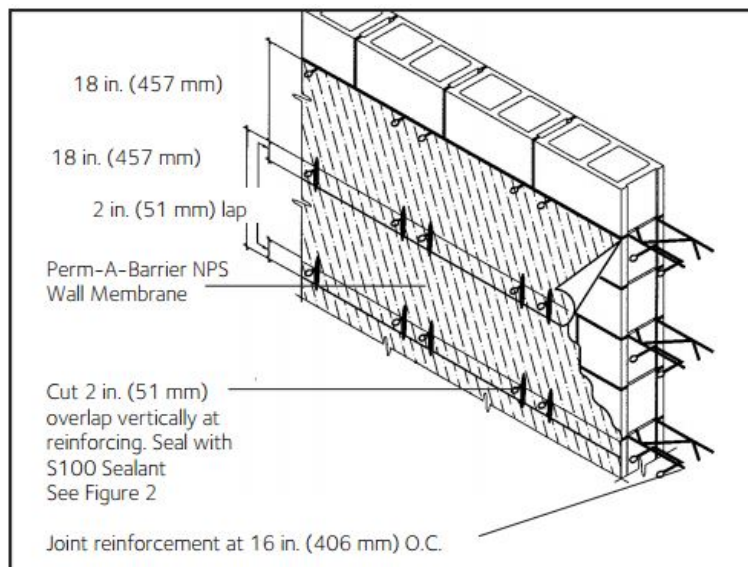
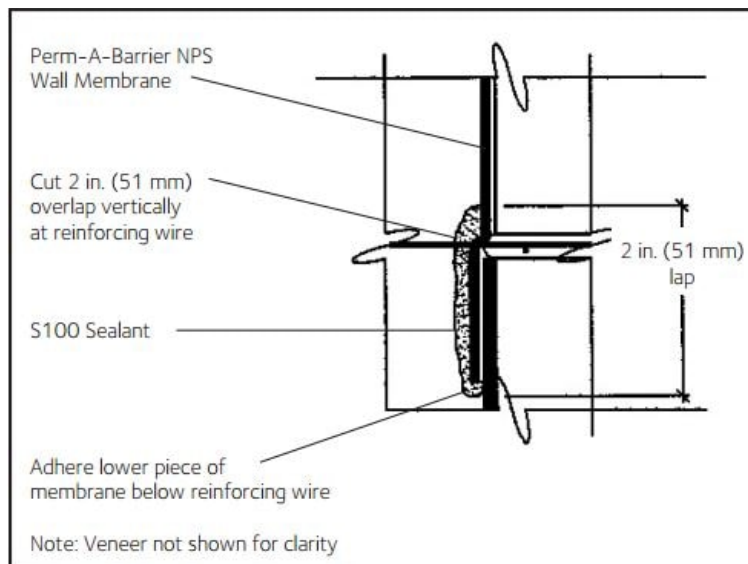

Figure 2: Horizontal Reinforcing



## Storage and Handling Information

All materials must be protected from rain and physical damage. Pallets of PERM-A-BARRIER®NPS Wall Membrane must not be double stacked on the job site. Provide cover on top and all sides, allowing for adequate ventilation. Store membrane where temperatures will not exceed 90°F (32°C) for extended periods. All products must be stored in a dry area away from high heat, flames or sparks. Store only as much material at point of use as is required for each day’s work.

## Limitations

PERM-A-BARRIER®NPS Wall Membranes must not be applied in areas where it will be exposed to direct sunlight permanently, and must be covered within 1 year. Refer to Technical Letter 19, *Exposure Guidelines for PERM-A-BARRIER®Self-Adhered Membranes*.

PERM-A-BARRIER®NPS Wall Membrane and all other PERM-A-BARRIER®self-adhered membranes should not be applied over PERM-A-BARRIER®S100 Sealant.

Maximum In Service Temperature (as installed) is 160°F (71°C)

## Warranty

PERM-A-BARRIER®products are warranted to be free of defects in manufacture for a period of 5 years. Material will be provided at no charge to replace any defective product.

## Technical Service

Support is provided by full-time technically trained GCP Applied Technologies field sales representatives and technical service personnel, backed by a central research and development technical services staff.

## Supply

PRODUCT	UNIT OF SALE	APPROXIMATE COVERAGE	WEIGHT	PALLETIZATION
PERM-A-BARRIER® NPS Membrane	1 roll	418 ft <sup>2</sup> (38.8 m <sup>2</sup> ) per roll 46 in. X 109 ft (1.17 x 33.22m) roll	59 lbs/roll	25 cartons (25 rolls) per pallet
PERM-A-BARRIER® Wall Flashing				
12 in. (305 mm)	3 rolls	75 linear ft per roll	25 lbs/roll	25 cartons (75 rolls) per pallet
18 in. (457 mm)	2 rolls	75 linear ft per roll	37.5 lbs/roll	25 cartons (50 rolls) per pallet
24 in. (610 mm)	1 roll	75 linear ft per roll	55 lbs/roll	25 cartons (35 rolls) per pallet
36 in. (914 mm)	1 roll	75 linear ft per roll	75 lbs/roll	25 cartons (25 rolls) per pallet
PERM-A-BARRIER® Aluminum Flashing				

6 in. (152 mm)	12 rolls	50 linear ft per roll	6 lbs/roll	30 cartons (360 rolls) per pallet
9 in. (225 mm)	6 rolls	50 linear ft per roll	9 lbs/roll	30 cartons (180 rolls) per pallet
12 in. (305 mm)	6 rolls	50 linear ft per roll	12 lbs/roll	30 cartons (180 rolls) per pallet
<hr/>				
BITUTHENE® Mastic - 5 gal pail	1 pail	approx. 120 ft <sup>2</sup> at 60 mils	54 lbs/pail	36 pails per pallet
<hr/>				
BITUTHENE® Mastic - 30 oz tube	12 tubes	approx. 30 linear ft x 1/4 in. bead	32 lbs/carton	72 cartons (864 tubes) per pallet
<hr/>				
PERM-A-BARRIER® S100 Sealant- 29 oz. Cartridge	1 cartridge	approx. 30 linear ft x 1/4 in. bead	29 oz. cartridge	10 cartridges/ carton 42 cartons/ pallet
<hr/>				
BITUTHENE® Liquid Membrane - 1.5 gal pail	1 pail	approx. 200 Linear ft/gal @ 1" wide x 90 mils.	16 lbs/pail	100 pails per pallet
<hr/>				
BITUTHENE® Liquid Membrane - 4 gal pail	1 pail	approx. 200 Linear ft/gal @ 1" wide x 90 mils.	44 lbs/pail	24 pails per pallet
<hr/>				
PERM-A-BARRIER® Adhesive - 5 gal pail	1 pail	250-300 ft <sup>2</sup> /gal (7-7m <sup>2</sup> /L)	43 lbs/pail	36 pails / pallet

## Physical Properties

PROPERTY	PERM-A-BARRIER NPS WALL MEMBRANE	TEST METHOD
Thickness includes HDPE Film	0.018 in. (0.46 mm)	ASTM D3767 method A
Minimum tensile strength, membrane	400 psi (2.8 MPa)	ASTM D412
Minimum tensile strength, film	5000 psi (34.5 MPa)	ASTM D412
Minimum elongation, to failure	200%	ASTM D412
Pliability, at 180° bend over 1 in. (25 mm) mandrel	Pass at -20°F (-29°C)	ASTM D1970
Crack cycling, 1/8 in. (3.2 mm) at -25°F (-32°C)	Pass	ASTM C1305
Nail Sealability	Pass	ASTM D1970
Minimum puncture resistance, membrane	40 lbs (178 N)	ASTM E154
Lap peel adhesion at minimum application temperature	3.5 lbs/in.	ASTM D1876
Maximum permeance to water vapor transmission	<0.01 perms / 0.02 perms	ASTM E96 Method A/ Method B
Water resistance of in-place membrane	Pass at >15 psf	ASTM E331
Air permeance of in-place membrane <sup>1</sup>	< 0.02 L/s/m <sup>2</sup> (0.004cfm/ft <sup>2</sup> )	ASTM E2178
Assembly air permeance at 1.57 psf (75 Pa) pressure difference <sup>1</sup>	< 0.02 L/s/m <sup>2</sup> (0.004cfm/ft <sup>2</sup> )	ASTM E2357

Water absorption (weight gain at 48 hours)	0.1%	ASTM D570
Wall assembly fire test	Pass as part of various wall assemblies with foam plastic insulation <sup>2</sup>	NFPA 285
Peel Adhesion to Gypsum board	>5 pli	ASTM D903
Peel adhesion to concrete	>5 pli	ASTM D903

**Footnote:**

1. Air permeance measured at a pressure differential of 1.57 psf (75 Pa).
2. Specific wall assemblies are available at [gcpat.com](http://gcpat.com).

[gcpat.com](http://gcpat.com) | North America customer service: 1-866-333-3726

We hope the information here will be helpful. It is based on data and knowledge considered to be true and accurate, and is offered for consideration, investigation and verification by the user, but we do not warrant the results to be obtained. Please read all statements, recommendations, and suggestions in conjunction with our conditions of sale, which apply to all goods supplied by us. No statement, recommendation, or suggestion is intended for any use that would infringe any patent, copyright, or other third party right.

BITUTHENE and PERM-A-BARRIER are trademarks, which may be registered in the United States and/or other countries, of GCP Applied Technologies Inc. This trademark list has been compiled using available published information as of the publication date and may not accurately reflect current trademark ownership or status.

© Copyright 2018 GCP Applied Technologies Inc. All rights reserved.

This document is only current as of the last updated date stated below and is valid only for use in the United States. It is important that you always refer to the currently available information at the URL below to provide the most current product information at the time of use. Additional literature such as Contractor Manuals, Technical Bulletins, Detail Drawings and detailing recommendations and other relevant documents are also available on [www.gcpat.com](http://www.gcpat.com). Information found on other websites must not be relied upon, as they may not be up-to-date or applicable to the conditions in your location and we do not accept any responsibility for their content. If there are any conflicts or if you need more information, please contact GCP Customer Service.

Last Updated: 2021-02-05

[gcpat.com/solutions/products/perm-a-barrier-nps-air-barrier/perm-a-barrier-nps-wall-membrane](http://gcpat.com/solutions/products/perm-a-barrier-nps-air-barrier/perm-a-barrier-nps-wall-membrane)