

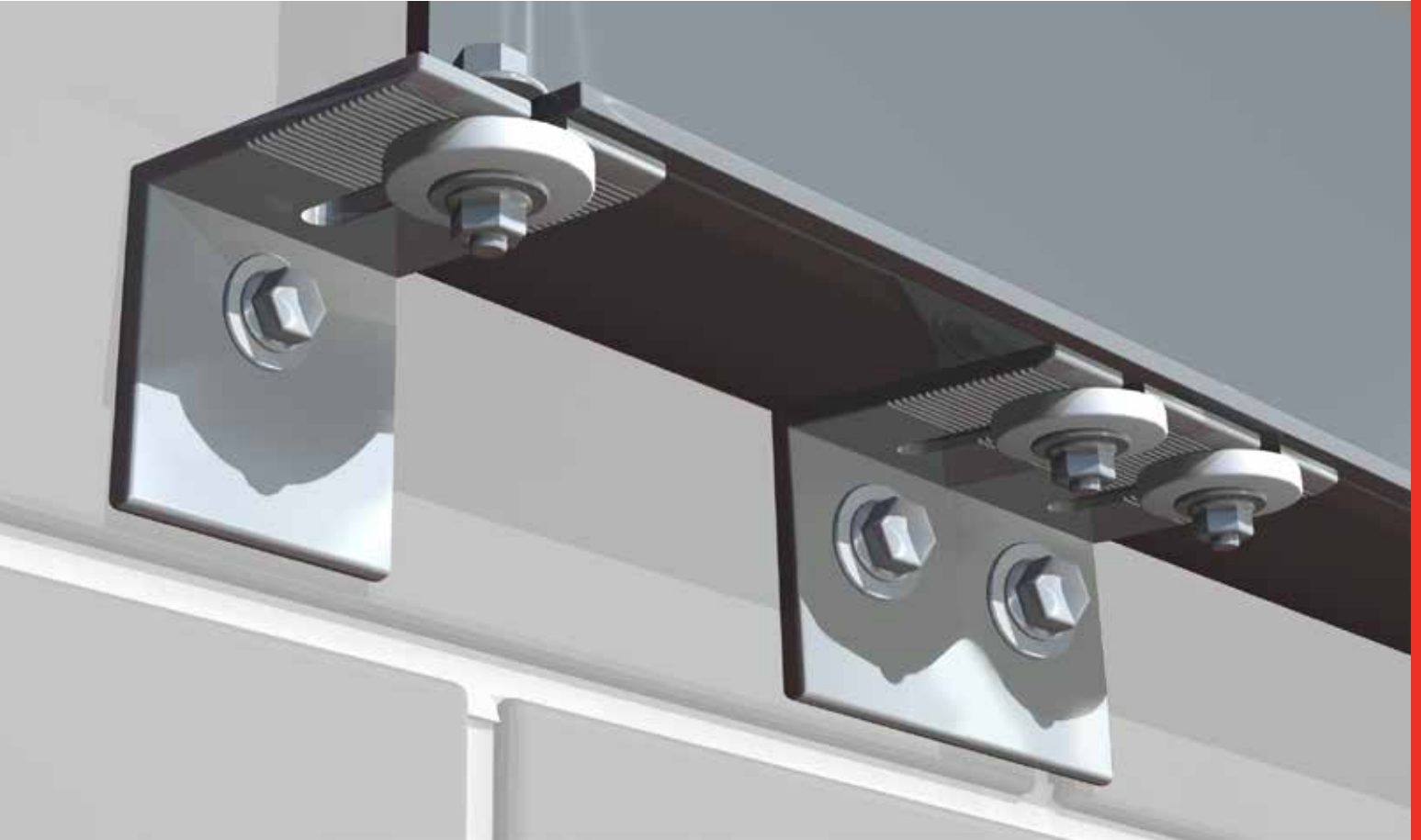

MASONPRO, Inc.
43300 Seven Mile Road
Northville, MI 48167
1-800-659-4731
www.masonpro.com

BREAK-AWAY™ FIRE-RELEASE CONNECTORS



***MAINTAIN FIREWALL INTEGRITY
EXTEND FIRE ESCAPE TIMES***

FERO Break-Away™ Fire-Release Connectors are designed to meet the National Building Code of Canada requirement that in the event of a fire a failing structural member may collapse without causing damage to the firewall.

COMPONENTS

This innovative break-away connector differs from conventional connectors by the use of a slotted support angle that allows for movement and total disengagement of the failing structural member caused by the melting of the fusible washer in the event of a fire.

Unlike other available fire release systems, the support angle of our system functions as a structural member under normal service conditions. Accordingly, the load bearing capacity of **FERO Break-Away™ Fire-Release Connector** is not limited by the load bearing capacity of the fusible washer.

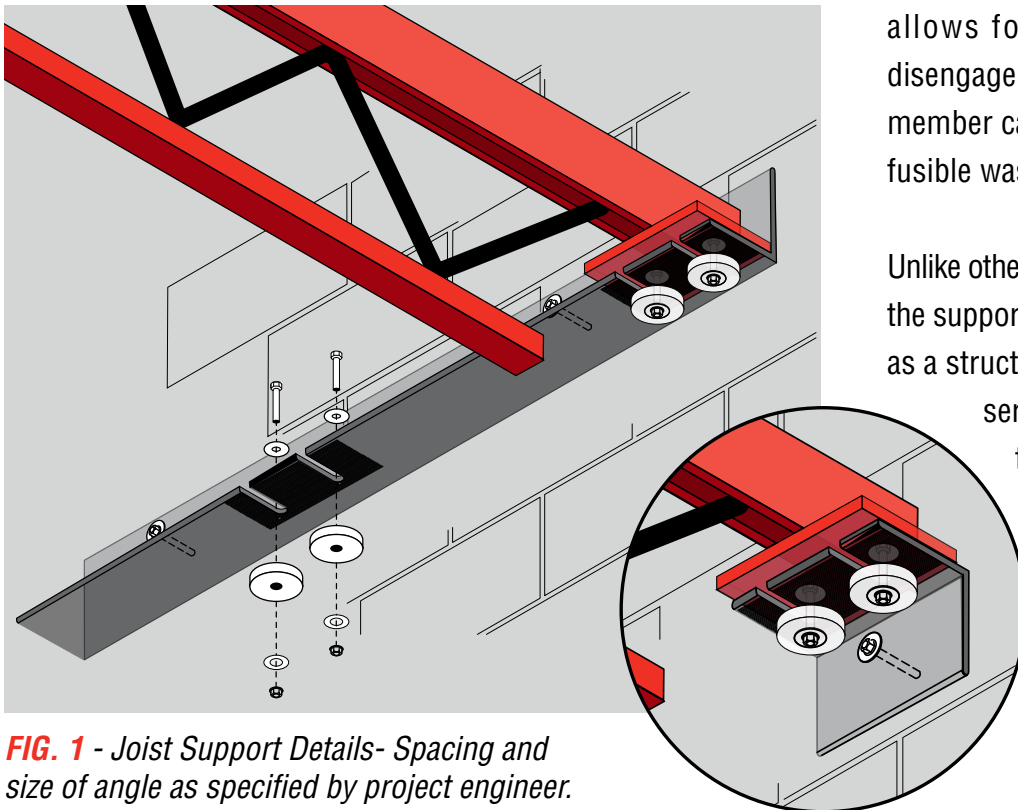

FIG. 1 - Joist Support Details- Spacing and size of angle as specified by project engineer.

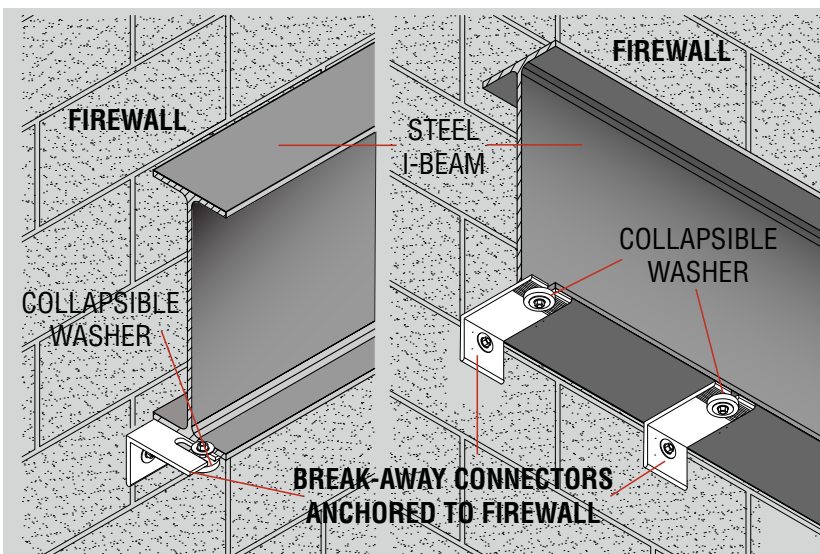

FIG. 2 – Beam Support Detail. For lateral support of the firewall

FERO Break-Away™ Fire-Release Connector:

- delays or prevents the collapse of firewalls in the event of a fire
- increases the fire escape time for occupants and firefighters
- minimizes the damage caused by fire
- maintains the structural capacity of the connection under normal service conditions.

INSTALLATION

FERO Break-Away™ Fire-Release Connectors consist of:

- a) a support steel angle connected to the firewall for securing a floor or ceiling to the firewall and
- b) a fusible washer with a lower melting point than the support angle.

The surface of the angle in contact with the washer is grooved for maximum lateral load resistance under normal conditions.

The fusible washer is made of Nylon having a melting point of approximately 260°C, which is much lower than that for the steel support angle. Nylon is commonly used in commercial products and generally has high chemical resistance. It has a heat deflection temperature of 75°C at 1.82 MPa, and a maximum resistance to continuous heat of 120°C, ensuring a satisfactory performance up to the point of fire.

The floor framing members are connected to the masonry firewall by a slotted steel angle that is bolted to the firewall. A fusible washer is placed between the nuts of the bolts securing the framing members and the steel angle. The slots in the angle allow for the movement of the floor framing when the fusible washer is softened or melted during a fire. This movement relieves the lateral stresses caused by the deformation of the framing members in a fire event, and under extreme deformations allows the framing members to disengage from the firewall.

It is beneficial to release the affected structural member from the firewall to separate the heat source from the firewall. This release allows the firewall to remain intact for a longer duration. As a result, firefighters would have sufficient time to prevent the spread of fire to adjacent spaces and occupants would be provided with sufficient time to escape before the firewall is compromised and the fire spreads.



FIG 3 – Connector Details

Other manufacturers have attempted to develop fire release systems. However, in all these systems, the anchor/connector is designed to melt in its entirety during a fire, causing total collapse of the structural framing solely due to heat, regardless of whether or not this is necessary to protect the firewall. Another major disadvantage of these systems manufactured by others is that, unlike FERO's system, the structural capacity of their support members is limited because the entire system is made of a material of low melting point.

TECHNICAL INFORMATION

Pre-engineered 152 mm long (6 inch) **FERO Break-Away™ Fire-Release Connector** is able to resist ultimate/factored loads from the flooring system up to the values given in TABLE 1.

TABLE 1 – DESIGN INFORMATION¹

Angle Dimensions (mm)		Vertical Resistance P_r (kN) ⁵	Bolt Diameter (mm)	Washer ⁴ Dimensions (mm)			Lateral Resistance per slot V_r (kN) ^{5,6}	Angle Configuration
L^2	t_a^3			D_{outer}	D_{inner}	t_w		
127	7.9	3.5	19	38	19	10.6	5.0	
	9.5	5.2						
	13	9.9						
	16	15.4						
	19	21.7						
152	9.5	4.3						
	13	8.2						
	16	12.6						
	19	18.1						
203	13	6.0						

1. Table values are the maximum vertical and lateral loads resisted by a support angle made of steel with a yield stress equal to 245 MPa. These values are for a discrete 150 mm (6 inch) long angle with two (2) slots and washers and assuming anchorage is sufficient for loads. Longer and/or continuous angles with more than two slots are able to resist higher loads.
2. Dimension is for the horizontal leg of the angle.
3. Angle thickness has been reduced in calculations by 10% to account for surface roughening.
4. Washer's material has the following properties: Compressive Strength of 100 MPa, Compressive Modulus of 2.9 GPa, and a coefficient of friction with steel of 0.4.
5. The maximum vertical and lateral resistances are based on the ultimate limit states design approach assuming the bolts used secure the connection to be ¾ inch in size (19 mm) and made of grade 4.6 ($F_y = 248$ MPa and $F_u = 413$ MPa).
6. Angle size does not change the value of the lateral load as it is governed by the slip resistance between the washer and steel angle.



15305 - 117 Avenue, Edmonton Alberta,
Canada T5M 3X4

TEL: (780) 455-5098 FAX: (780) 452-5969

www.ferocorp.com

E-mail: engineering@ferocorp.com



Copyright © 2014-2021 FERO Corporation

FERO® and Break-Away™ are registered trademarks of FERO Corporation.
Patented – US 8,490,340; US 8,490,341; US 8,955,263; US 9,234,344; CA 2 738 488;
CA 2 751 858; CA 2 769 821; CA 2 865 824.

PRINTED IN CANADA